

 **SteamBase**



**OVEN**

**VRM9651B**

60 CM. BUILT-IN OVEN  
9 Programs | 65 Litres

**EAN**  
8858787031036

**PRICE**  
THB 19,900.-

Unit price in THB is  
inclusive of 7% VAT.

## 9 VERSATILE AND PRACTICAL PROGRAMS



### Bottom Heating

Ideal for slow cooking, keeping cooked food warm.



### Top Heating

Ideal for browning food.



### Top and Bottom Heating

Ideal for traditional static cooking for one shelf only.



### Top and Bottom Heating with Fan Assisted

The heat in the oven is distributed homogeneously thanks to the fan.



### Turbo Heater and Fan

The heat is distributed homogeneously thanks to the fan and ring heater and more than one food can be cooked.



### 3D Cooking

The optimal homogeneous heat distribution all over cooking trays. More fluffy pasties.

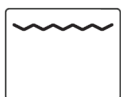

### Grill

Ideal for mixed grills.

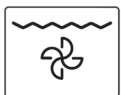

### Grill and Fan

Homogeneous heat distribution occurs thanks to the fan.



### Oven Light

MEX stylish black built-in oven helps you create variety of menu for the whole family. With 9 programs selection in generous 65 litre capacity, it gives you plenty of space and 5 shelf position with removable side racks, letting it easily handle varying cooking style. This also offers a solution to all your cooking needs that make your meals perfect.

Moreover, this MEX built-in oven provides precise and consistent temperature control for the best cooking result.

## 3D COOKING TECHNOLOGY



Simultaneous operation of top, bottom and ring heating element with fan. This 3D Cooking technology helps;

- Homogeneous heat distribution in all direction of cooking tray, ensuring consistently even cooking.
- Automatic power management for heaters during operation
- Cooking time is 20% shorter than conventional cooking functions.
- Pre-heating time is 25% shorter than conventional cooking functions.

## BUILT-IN OVEN VRM9651B

### SteamBase TECHNOLOGY



“*Steam Base*” Technology combines steam with traditional cooking functions utilizing the evaporation of the water inside the oven cavity.

Steam cooking reduces the loss of moisture in meat-type foods, while the inside is more juicy and the outside is more crispy, while the pastry makes the foods more puffy, crispy and bulky on the outside.

### REMOVABLE INNER GLASS AND OVEN DOOR



#### Removable Inner Glass

Easy to remove the inner glass without any tools.



#### Easy to remove oven door

It is easy removing the oven door by flipping up the hinge latches.



#### Easy Clean

Advanced easy to clean coating on inner door glass. A quick wipe with a damp microfiber and a few cleaning agent is enough.

### EASY TO CLEAN



#### Steam Cleaning

With this technology, dried food leftovers inside the oven cavity are softened with vapor. To perform *Steam Cleaning* add 300ml. of water into water tank. After that, *Steam Cleaning* is activated to create vapor inside oven cavity which will soften dried food stains.



#### Easy to Clean Enamel (ETC)

This MEX built-in oven has special formula of Easy to Clean Enamel (ETC) to prevent dirt sticking to the inner walls. It is easier to clean.

### ACCESSORIES



1 x Enamel tray



1 x Wire shelf with stopper



1 x Small Enamel tray



## BUILT-IN OVEN VRM9651B

### FEATURES

MEX stylish black built-in oven helps you create variety of menu for the whole family. This oven provides precise and consistent temperature control for the best cooking result, offering a solution to all your cooking needs that make your meals perfect.

- 60 cm. multi-function electric built-in oven
- Material : Black glass / Stainless steel
- 65 litres capacity
- 9 programs with 3D cooking
- "Steam Base" Technology reduces the loss of moisture in foods, while the inside is more juicy
- Easy to clean with *Steam Cleaning* technology
- Maximum cooking temperature 260°C
- 3 eye-catching knob controls:
  - Program
  - Temperature
  - Timer
- Double glasses Ventilated Cool Door
- Removable inner glass
- Easily remove oven door by flipping up the hinge latches
- 5 side wire racks
- 1 x 25 watt interior lighting
- Accessories included 1 enamel tray 1 wire shelf and 1 small enamel tray
- Energy Efficiency Class : A
- Made in Europe

### ISOMETRIC VIEW

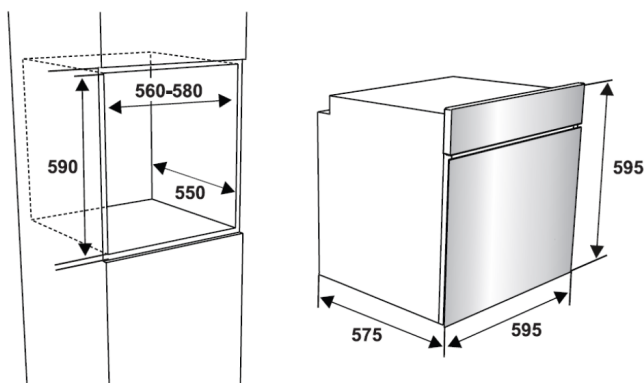

### SPECIFICATION

#### PRODUCT MEASUREMENT

Overall Dimension W595 x D575 x H595 mm.

Net Weight 28.0 Kg.

#### PACKAGING MEASUREMENT

Overall Dimension W660 x D655 x H640 mm

Gross Weight 32.83 Kg.

#### INSTALLATION REQUIREMENT

Cutting Size W560 x D550 x H590 mm

#### IMPORTANT SAFTY INFORMATION

Power Supply 220-240V / 50Hz.

Nominal Power 2.6 kW

### INSPIRATION

